



24208-80

(776—77)

. . . (); . . .

. . . »

27 1980 . N3 2381 -

24208-80

(776 77)

Mapered adapter sleeves of rolling bearings.
Basic dimensions.

8725-67

1960 . 2381

без ограничения
числ 10-91

²⁷
с 01.07. 1980 г.
~~до 01.04. 1998 г.~~

1.

1:12

776 77.

2.

. 1 2

. 1-6.

200

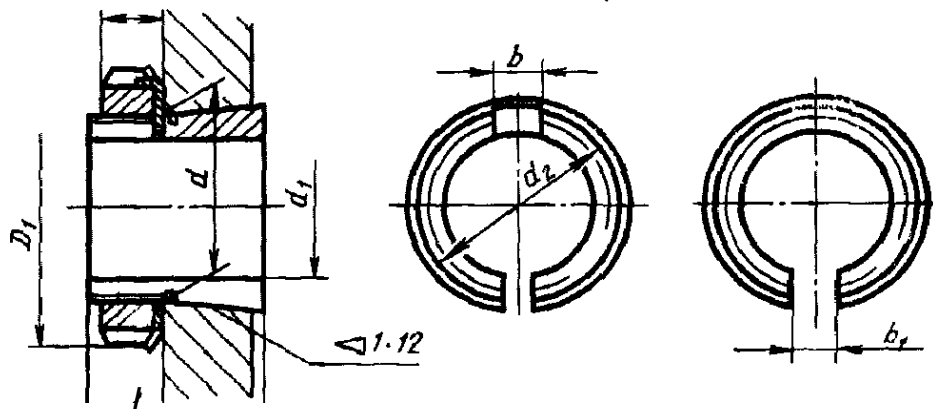

. 1

©

, 1980

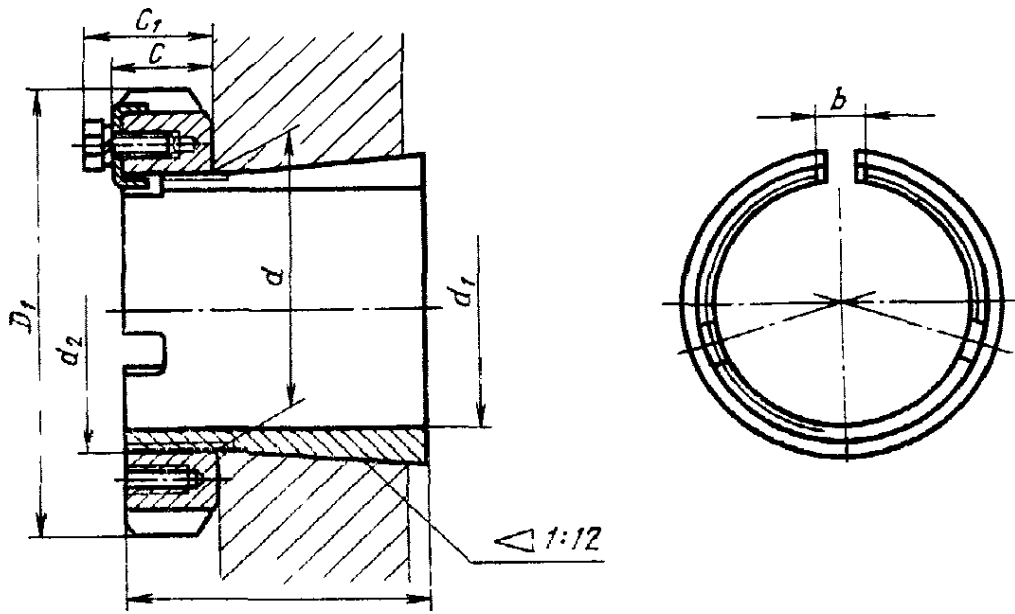

.2

.1 2.

d —
 d_1 —
 d_2 —
 D_1 —
 l —
 C_1 —

C_1 —

d_1 d_2

3.

(,)

4.

400 /

5.

8530—57.

6.

3325—55.

2,

0

I

	d	dx	$d_{\%}$						
204	20	17	20X1	24	4	8	7	32	0,041
205		20	25X1,5	26	5	8	8	38	0,070
206	30	25	M30XU5	27	5	8	8	45	6,099
207	35	30	35X1,5	29	6	8	9	52	0,125
208	40	35	40x1,5	31	6	10	10	58	6,174
206	45	40	45 1	33	6		11	65	0,227
210	50	45	50X1,5	35	6	10	12	70	6,274"
211	55	50	55 2	37	8	10	12	75	0,308
212	60	55	60 2	38	8	10	13	80	0,346
213	65	60	65 2	40	8	10	14	85	0,401
214	70	60	70 2	41	8	12	14	92	0,593
215	^5	65	75X2	43	8	12	15	98	6,707
216	'^6	70	80 2	46	10	12	17	105	0,882
"217	85	75	85X2	50	10	12	18		1,020
21»	90	80	90X2	52	10	14	18	120	1,190
220	100	90	0 2	58	12	14	20	130	1,490
222	[110	100	MI 10x2	63	12	16	21	145	1,930

2

3,

		dx	d_B	1			€ «	Dx «	
304	20	17	20 1	28	4	8	7	32	0,045
305	25	20	M25XU5	29	5	8	8	38	6,075
306	30	25	30X1,5	31	5	8	8	45	6,109
307	35	30	35 1.	35	6	8	9	52	6,142
308	40	35	40 1.5	36	6	10	10	58	0,189
309	45	40	46X1,5	39	6	10	11	65	0,248
310	50	45	60 1.5	42		10	12	70	0,303
311	55	50	55 2	45	8	10	12	75	6,345
312	60 '	55	60 2	47	8	to	13	80	0,394
313	65	60	65 2	50	8	10	14	85	6,41.8
314	70	60	70 2	52	8	12	14	92	0,728
315	75	5	75 2	55	8	12	15	98	0,831
318	80	70	80 2	59	10	12	17	105	1,030
317	85	75	85 2	63	10	12	18		1,180
318	90	80	90X2	65	10	14	18	120	1,370
320	15 90	90	1 0 2	71	12	14 '	20	130	1,690
322	110	100 '	110X2	77	12	16	21	145	27

3(6),

0

	<i>d</i>	<i>dx</i>	<i>d</i> _%	<i>l</i>	<i>b</i>	6i	C ft!	C/ ft!	<i>Dx</i>	ft!
2304	20	17	M2QX1	31	4	8	7	—	32	0,049
2305	25	20	25 1,5	35	5	8	8	—	38	0,087
2306	30	25	30 1.5	38	5	8	8	—	45	0,126
2307	35	30	35 1.5	43	6	8	9	—r	52	0,165
2308	40	35	M4QX1.5	46	6	10	10	—	58	0,224
2309	45	40	45 1.5	50	6	10	11	—	65	0,280
2310	50	45	50 1 »5	55	6	10	12	—	70	0,362
2311	55	50	55 2	59	8	10	12	—	75	0,420
2312	60	55	60 2	62	8	10	13	—	80	0,481
2313	65	60	65 2	65	8	10	14	*	85	0,557
2314	70	60	70 2	68	8	12	14	—	92	0,897
231(5)	75	65	76 2	73	8	12	15	—	98	1,05
2316	80	70	80 2	78	10	12	17	—	105	1,28
2317	85	75	M8I5X2	82	10	12	18	—	110	1,45
2318	90	80	M90Xi2	86	10	14	18	—	120	1,69
2320	100	90	0 2	97	12	14	20	—	130	2,15
2322	110	100	MI 10X2	105	12	16	21	—	145	2,74
2324	120	110	0 2	112	14	16	2d	—	155	3,19
2326	130	115	M130IX2	121	14	18	23	—	165	4,60
2328	140	125	140 2	131	16	18	24	—	180	5,55
2330	150	135	MI 50X2	139	16	20	26	—	195	6,63
2332	160	140	M160X3	J 47	18	20	28	—	210	9,14
2334	170	150	MI 70X3	154	18	22	29	—	220	10,2
2336	180	160	M180X3	161	20	22	30	—	230	11,3
2338	~ 5	170	Mil 90X3	169	20	24	31	—	240	12,6
2340	200	180	M200X3	176	20	24	32	*	250	13,9
2344	220	200	Tr220X4	186	20		36	44	280	6,7
2348	240	220	Tr240x4	199	20		38 -	46	300	19,7
2352	260	240	Tr260X4	211	24	— i	40 J	50	330 !	24,2
2356	280	260	Tr28Qx4	224	24	— i	42 <	52	350 :	27,8

1, 3

	<i>d</i>	*	<i>d_t</i>	1				<i>C_i</i>	«	«
3024	120	110	120 2	72	14	16	22		145	1,93
3026	130	115	1 0 2	80	14	18	23	—	155	2,85
3028	140	125	140 2	82	16	18	24	—	165	3,16
3030	150	135	160X2	87	16	20	26	—	180	3,89
3032	160	140	160	93	18	20	28	—	190	5,21
3034	170	150	170	101	18	22	29	—	200	5,99
3036	1*80	160	180	109	20	22	30	—	210	6,83
3038	190	170		112	20	24	31	—	220	7,45
3040	200	180	200	120	20	24	32	— :	240	9,19
3044	220	200	220 4	128	20	—	34	40	260	10,3
3048	240	220	240 4	133	20	—	38	46	290	13,2
30(52	260	240	260 4	147	20	—	38	46	310	15,3
3056	280	260	280 4	152	24	—	42	50	330	17,7
3060	300	280	300 4	168	24	—	46	54	360	22,8
3064	320	300	320 5	171	24	—	47	55	380	24,6
3068	340	320	340 5	187	24	—	50	58	400	28,7
3072	360	340	360 5	188	28	—	50	58	420	30,5
3076	380	360		193	28	—	53		450	35,8
3080	400	380	400 5	210	28	—	57	67	470	41,3
3084	420	400	420 5	212	32	—	57	67	490	43,7
3088	440	410	440 5	228	32	—	65	77	520	65,2
3092	460	430	460 5	234	32	—	65	77	540	69,5
3096	480	450	480 '5	237	36	—	65	77	560	73,3
30/500	500	470	50 5	247	36	—	73	85	580	81,8
30/530	530	600	530 6	265	40	—	75	90	630	100,0
30/560	560	530	560	282	40	—	82	97	650	110,0
30/600	600	560	600x6	289	40	-	82	97	700	146,0
30/630	630	600		301	45		82, 97	97	730	136), 0
30/670	670	630		324	45	-	87	102	780	194,0
30/7)	710	670	710 7	342	50	—	97	112	830	12 23,0

7,

3

		«1	$d_{\%}$						Dt	
3120	100	90	100 2	76	12	14	20	—	130	1,78
3122		100	MI 10x2	81	12	16	21	—	145	2,25
3124	120	110	120 2	88	14	1	22	—	155	2,64
3126	130	115	130 2	92	14	18	23	—	165	3,66
3128	140	125	140 2	97	16	18	24		180	4,34
3130	150	135	MI 50X2	111	16	20	26	—	195	5,52
3132	160	140	160	119	18	20	28	—	210	7,67
3134	170	150	170	122	18	22	29	—	220	8,33
3136	180	160	180	131	20	22	30	—	230	9,50
3138	190	170	190	141	20	24	31	—	240	10,8
3140	200	180	200	150	20	24	32	—	250	12,1
3144	220	200	220 4	161	20	—j	36	44	280	14,7
3148	240	220	240 *	172	20	—	38	46	300	17,3
3162	260	240	260 4	190	24	—	40	49	330	22,0
3156	280	260	280 4	195	24	—	42	51	350	24,5
3160	300	280	0 4	208	24	—	44	53	380	30,2
3164	320	300	320 5	226	24	—	47	56	400	34,9
3168	340	320	340 5	254	28	—	60	72	440	49,5
3172	360	340		259	28	—		75	460	54,2
3176	8	360	380	264	32	—	66	77	490	61,7
3180	400	380	400 5	272	32	—	67	82	520	70,6
3184	420	400	420 6	304	37	—	75	90	540	84,2
3188	440	410	440 5	307	36	—	75	90	560	104,0
3192	460	430	460 5	326	36	—	80	95	~ ~	116,0
3196	480	450	480 5	335	36	—	80	95	620	133,0
31/500	500	470	TrSOOXs	356	40	—	85	100	630	143,0
31/530	530	500		364	40	—	87	105	670	161,0
31/560	660	530	560	377	45	—	92		716	185,0
31/600	600	560		399	45	—	92	116	750	^

2,

3

	<i>d</i>	<*	<*»	<i>l</i>			<i>C_i</i> <i>ft!</i>	<i>Dt</i>	«
3260	300	280	Tr300iX4	240	24	44	.54	380	34,1
3264	320	300	Tr320x5	258	24	47	57	400	39,3
3268	340	320	340 5	288	28	60	72	440	54,6
3272	360	340		299	28	63	75	460	60,6
3276	380	360	380 5	310	32	65	77	490	69,6
3280	400	380	400 5	328	32	67	82	520	81,0
3284	420	400	420	352	32	75	90	540	94,0
3288	440	410	440 5	361	36	75	90	560	218,0
3292	460	430	460 5	382	36	80	95	580	132,0
3296	480	450	480 5	397	36	80	95	620	152,0
32/500	500	470		428	40	85	100	630	166,0

7,85 / 3.), . 1—6 (*
 2, 0 -
 70 ; -
 7. 214 24208—80
 ()

24208—80		24208—80		24208-80	
204	204	315	316	2332	632
206	205	316	315	2334	634
206	206	317	317	2336	636
207	207	318	318	2338	636
208	208	320	320	2340	640
209	209	322	322	3024	124
210	210	2304	604	3026	126
211	2L1	2305	605	3028	128
212	2	2306	606	3030	130
213	213	2307	607	3032	132
216	215	2308	608	3034	134
216	216	2309	609	3036	136
217	217	2310	630	3068	138
218	218	2311	611	3040	
220	220-	2312	612	3122	722
222	222	2313	613	3124	724
304	304	2315	615	3126	726
305	305	2316	616	3128	728
306	306	2317	617	3130	730
307	307	2318	618	3132	732
308	1	2320	620	3134	734
309	309	2322	622	3136	736
310	310	2324	624	3138	738
311	311	2326	626	3140	740
312	312	2328	628	—	
31.3	313	2330	630	—	—

. 03.06.80 , . 19.08.80 0,75 . . 0,62 .- . . . 20000 3 .
« » , 123657, , 256. . 1813 -# ft